

**CLEAN DEVELOPMENT MECHANISM
PROJECT DESIGN DOCUMENT FORM (CDM-SSC-PDD)
Version 03 - in effect as of: 22 December 2006**

CONTENTS

- A. General description of the small scale project activity
- B. Application of a baseline and monitoring methodology
- C. Duration of the project activity / crediting period
- D. Environmental impacts
- E. Stakeholders' comments

Annexes

Annex 1: Contact information on participants in the proposed small scale project activity

Annex 2: Information regarding public funding

Annex 3: Baseline information

Annex 4: Monitoring Information

CDM – Executive Board

Revision history of this document

Version Number	Date	Description and reason of revision
01	21 January 2003	Initial adoption
02	8 July 2005	<ul style="list-style-type: none">• The Board agreed to revise the CDM SSC PDD to reflect guidance and clarifications provided by the Board since version 01 of this document.• As a consequence, the guidelines for completing CDM SSC PDD have been revised accordingly to version 2. The latest version can be found at http://cdm.unfccc.int/Reference/Documents.
03	22 December 2006	<ul style="list-style-type: none">• The Board agreed to revise the CDM project design document for small-scale activities (CDM-SSC-PDD), taking into account CDM-PDD and CDM-NM.

 CDM – Executive Board

SECTION A. General description of small-scale project activity
A.1 Title of the small-scale project activity:

>>

The Consteel energy efficiency project at Cape Gate, South Africa
Version 2
31/01/2012

A.2. Description of the small-scale project activity:

>>

Purpose of the Project:

This project reduces the energy intensity of steel production, which leads to a reduction of Green House Gas (GHG) emissions from the baseline, which is the business as usual steel production.

The pre-project scenario consisted of a AC, manual top feed, electric arc furnace (EAF). Since the installation of this furnace in 1980, maintenance and modifications to the furnace has been done to the point where the maximum capacity of 500,000 tons per annum has been reached for the current furnace. To increase the capacity of the existing technology, a larger furnace will need to be installed.

The Consteel technology, which was implemented in this project, reduces energy consumption of steel production, while also increasing the output capacity of the current furnace without the requirement to install a larger furnace. This technology also improves the working environment, constantly controlling fume emissions and noise.

Davsteel, the steel manufacturing division of the Cape Gate (Pty) Ltd group (hereafter referred to as Cape Gate), is situated in Vanderbijlpark, Gauteng. Davsteel's main product range includes:

- reinforcing bar in straight lengths as well as coils;
- light section profiles i.e. angles, flats and squares; and
- wire rod for the processing of wire and wire products.

A Consteel system was installed for feeding the existing electric arc furnace (EAF) at Davsteel's meltshop in Vanderbijlpark. The installation was a retrofit/modification to the exiting EAF. Using the Consteel process, electricity intensity can be reduced in the Meltshop of Cape Gate (Brown, Levine, & Short, 2000). Tenova Melt Shops claims overall electricity energy savings between 80-120 kWh/ton liquid steel (tls) (Tenova Melt Shops, 2009).

Consteel is an innovative melting technology and the installation at Cape Gate was the first in South Africa (Memoli & Ferri, 2008). It is the only commercial technology that is able to continuously feed and preheat the metallic charge to EAF while keeping the gaseous emissions under control, without additional energy consumption (Fanutti & Pozzi, 2004).

GHG Reduction:

With the installation of the more energy efficient technology, the energy requirements per ton of steel produced (kWh/t) decreased. Cape Gate currently imports electricity from the national grid (of which Eskom is the service provider to for grid electricity).

CDM – Executive Board

South African grid electricity is generated predominantly from low grade coal, which means that it is emissions-intensive. Improvement in energy efficiency (i.e. reduction of grid electricity usage) will lead to GHG emissions reductions.

Contribution to Sustainable Development:

The project makes a positive contribution to sustainable development. The South African Designated National Authority (DNA) evaluates sustainability in three categories: economic, environmental, and social. The contribution of the programme towards sustainable development is discussed below in terms of these three categories:

Environmental

The project has a positive environmental impact by reducing electricity requirements from the largely coal based South African grid. These positive impacts relate to a reduction in the generation of coal-based electricity and its associated environmental impacts. These impacts include: the impact of coal mining, the utilisation of scarce water resources, SO₂ emissions, particulate emissions, the environmental impacts associated with the mining and transportation of coal and the impacts associated with the disposal of coal ash.

The project has a positive impact on the local environmental quality by means of reduction in noise, dust, and other furnace off-gas pollutants (Fanutti & Pozzi, 2004).

There will be no change in the usage of natural resources, or impacts on biodiversity and ecosystems in this project.

Economic

South Africa's national electricity provider, Eskom, carried out planned electricity supply interruptions at the beginning of 2008. These interruptions were caused by the demand for electricity exceeding the supply of electricity. During the interruptions, grid electricity was not accessible. Promoting energy efficiency in South Africa will reduce the pressure on the current energy infrastructure, thereby making important contributions the country's economic sustainability.

There will be a transfer of knowledge from the countries supplying the energy efficient technology to South Africa, and the project will contribute to foreign reserve earnings for South Africa via carbon credit sales revenue.

With the new technology, local skills will be developed. This project also has the potential to be replicated at other steel manufacturers in South Africa.

Social

The programme created jobs in the construction phase. The implementation of the project improved the working conditions of the people operating the furnace.

General

CDM – Executive Board

The project are generally acceptable, seeing as there are many benefits such as local job and skills development, as well as aligning with national energy efficiency and emission reduction targets. Distribution of the project's benefits is deemed to be reasonable and fair.

A.3. Project participants:

>>

Name of Party involved (*) (host) indicates a host Party)	Private and/or public entity(ies) project participants (*) (as applicable)	Kindly indicate if the Party involved wishes to be considered as project participant (Yes/No)
Republic of South Africa (host)	<ul style="list-style-type: none"> • Cape Gate (Pty) Ltd (Private entity A) • Nedbank Capital (Private entity B) 	No

The contact information on all project participants has been provided in Annex I.

A.4. Technical description of the small-scale project activity:

A.4.1. Location of the small-scale project activity:

>>

A.4.1.1. Host Party(ies):

>>

Republic of South Africa.

A.4.1.2. Region/State/Province etc.:

>>

The project is located in the Gauteng Province.

A.4.1.3. City/Town/Community etc:

>>

The town the project is located in is Vanderbijlpark.

A.4.1.4. Details of physical location, including information allowing the unique identification of this small-scale project activity :

>>

The project activity is located at the co-ordinates: 26.658781°S, 27.855223°E

Property description: Erf 2, NE 3 Vanderbijlpark

See figures below for illustration of project location on maps.



Figure 1: Map of Gauteng

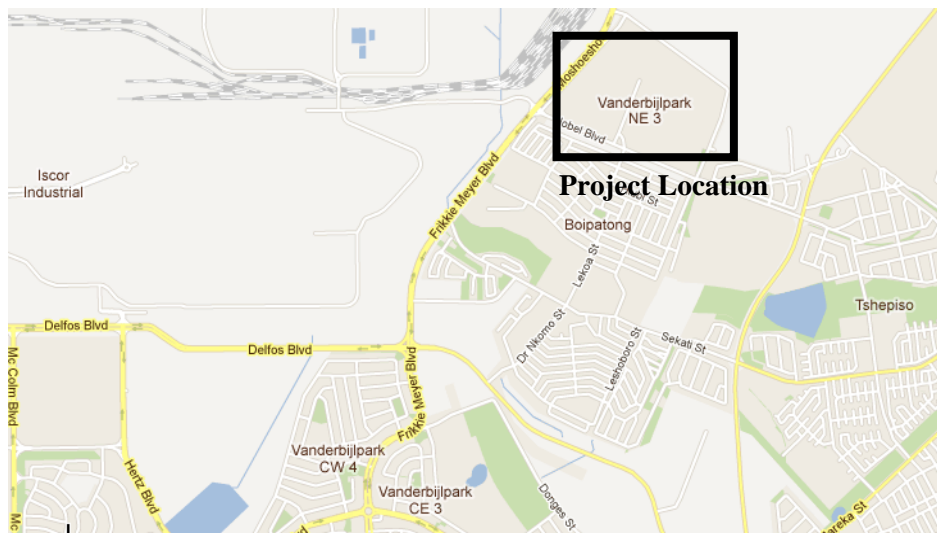

Figure 2: Map of Vanderbijlpark

A.4.2. Type and category(ies) and technology/measure of the small-scale project activity:

>>

The project activity has helped in GHG abatement by reducing the electricity consumption during steel-making through modification of the EAF by installing the Consteel system to the furnace i.e. making the steel production in the EAF less energy intensive.

Type and category of the proposed project activity:

Type II - Energy Efficiency Improvement Projects
 Project Category - II.D. Energy efficiency and fuel switching measures for industrial facilities,
 Version 12
 (Sectoral Scope 4)

Technology description:

CDM – Executive Board

The pre-project scenario at Davsteel was the operation of one batch-fed Tegliaferri AC EAF of 76 metric ton tap weight, equipped with a 65 MVA transformer and three water-cooled Techint KT burner/lances, one door burner and three Techint KT carbon injectors. The electrical digital regulation is Techint TDR-H. Davsteel also runs an EFSOP[®] Holistic Optimisation[™] system (Scipolo, Khan, Patil, & Holmes, 2008).

For the project activity, all the pre-project scenario equipment is still intact and working. The only difference is the addition of the energy efficient Consteel system.

Energy efficiency in the Consteel system is achieved by using the hot exhaust gasses of the furnace to pre-heat the feed going into the furnace. The system is supplied by Tenova Melt Shops. It is the only commercial process that continuously feeds and preheats the charge to the EAF while simultaneously controlling the gaseous emissions (Tenova Melt Shops, 2009). The Consteel system is a retrofit/modification to the existing EAF at Cape Gate and was commissioned in January 2010.

In general, the Consteel process consists of a conveyor belt which carries the scrap steel used as raw material in the steel making process through a tunnel, down to the EAF through a hot heel. The conveyor belt continuously transports the scrap steel charge to the EAF, while the charge is preheated by off gases leaving the furnace. The preheating of the raw material to the EAF is one of the main differing characteristics with other steel production methods. After the hot gasses was used to preheat the scrap steel, it is sent to a fume-cleaning plant where carbon monoxide and pollutants are burned in a combustion chamber without consuming fuel (Tenova Melt Shops, 2009).

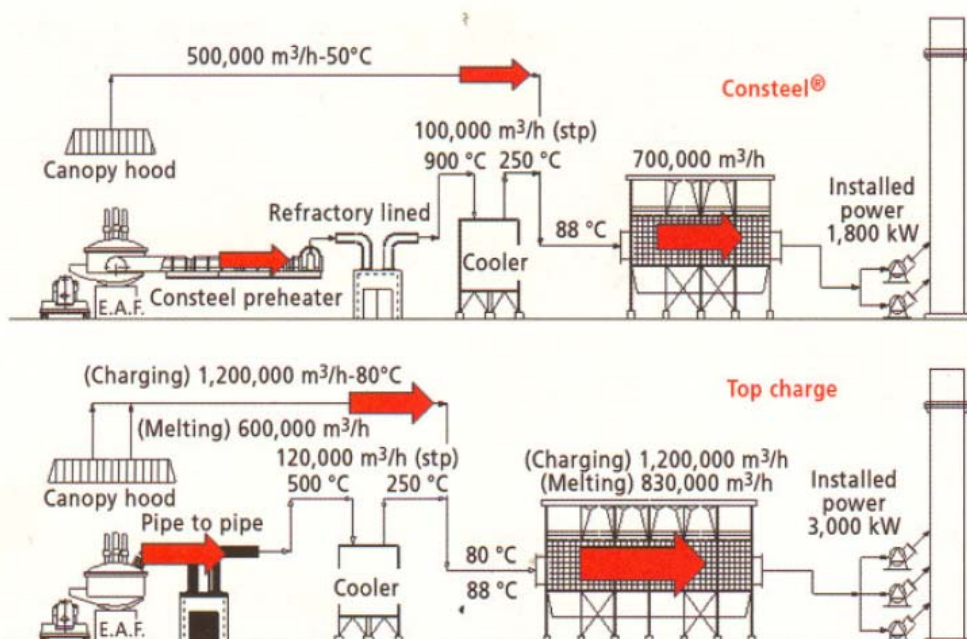

Figure 1: Off-gas treatment in a Consteel plant, compare to a conventional EAF plant (Memoli & Ferri, 2008).

The main benefits of the Consteel system are electricity savings of between 80-120 kWh/ton and a significant decrease in electrical disturbances on the network (Tenova Melt Shops, 2009). The reduction of total energy required for melting has a tremendous impact on the reduction of GHG emissions (Tenova Melt Shops, 2009). The Consteel equipment is designed for high reliability and low maintenance, including reduced refractory maintenance. The result is a safer, more congenial working environment compared to typical conditions in the steel industry (Tenova Melt Shops, 2009).

CDM – Executive Board

The Consteel process is an environmentally safe and sound technology, and has been installed in Annex I countries where the pollution limits are very strict such as Japan, Europe, and USA and it fulfils their environmental regulations without the need of a special gas treatment. The stack emissions comply with the strictest industry standards (Fanutti & Pozzi, 2004).

Tenova, the supplier of the Consteel technology is an international company. There is a technology transfer to South Africa seeing as the Consteel process installed at Cape Gate will be the first-of-its-kind in South Africa. Employees of Cape Gate will receive the required training to operate the Consteel equipment.

The implementation of the Consteel Process at Davsteel was achieved by keeping the existing EAF and changing the feed arrangement by installing the Consteel pre-heater. The project implementation therefore involved:

Existing equipment retained in project	New Equipment
Electric Arc Furnace	Preheat conveyor
Transformers	
Gas cleaning plant	

A.4.3 Estimated amount of emission reductions over the chosen crediting period:

>>

Year	Annual estimation of emission reductions in ton CO ₂ e
1	30,066
2	30,066
3	30,066
4	30,066
5	30,066
6	30,066
7	30,066
8	30,066
9	30,066
10	30,066
Total estimated reductions (ton CO₂e)	300,660
Total number of crediting years	10
Annual average over the crediting period of estimated reductions (ton CO₂e)	30,066

A.4.4. Public funding of the small-scale project activity:

>>

No public funding has been used or will be used in the development and implementation of this project.

A.4.5. Confirmation that the small-scale project activity is not a debundled component of a large scale project activity:

As per “Appendix C” of the “Simplified Modalities and Procedures for Small-Scale CDM project activities”, debundling is defined as the fragmentation of a large project activity into smaller parts. A small scale project activity that is a part of a large project activity is not eligible to use the simplified

CDM – Executive Board

modalities and procedures for small-scale CDM project activities. Therefore the project proponent is required to establish that the project activity under consideration is not a debundled component of a large project activity in order to make use of the simplified modalities and procedures for small-scale CDM project activities. The same is demonstrated below:

“A proposed small-scale project activity shall be deemed to be a debundled component of a large project activity if there is a registered small-scale CDM project activity or an application to register another small-scale CDM project activity:

- *With the same project participants;*
- *In the same project category and technology/measure;*
- *Registered within the previous 2 years; and*
- *Whose project boundary is within 1 km of the project boundary of the proposed small-scale activity at the closest point.”*

The project proponent confirms that it has not registered any small scale CDM activity, or applied for registration of another small scale CDM project activity within 1 km of the project boundary of this proposed project, in the same project category and technology/measure. Hence the above criteria of debundling cases are not applicable for this proposed CDM project.

SECTION B. Application of a baseline and monitoring methodology

B.1. Title and reference of the approved baseline and monitoring methodology applied to the small-scale project activity:

>>

According to the Appendix B of the simplified modalities and procedures for small-scale CDM project activities of the UNFCCC, the following approved small-scale baseline and monitoring methodology is applied to the project activity under consideration:

Type II – *“Energy Efficiency Improvement Projects”*

Project Category - D – *“Energy efficiency and fuel switching measures for industrial facilities”* (version 12.0)

Tool used for emission reduction calculation:

“Tool to calculate the emission factor for an electricity system” (version 02.2.1)

B.2 Justification of the choice of the project category:

>>

This project activity meets all the conditions set forth in the approved methodology AMS-II.D, hence the selected methodology is appropriate for the project activity.

A discussion on the applicability of AMS-II.D. as applied to this project activity follows:

Technology/measure as per AMS-II.D	Applicability to this project activity
<p>1. <i>This category comprises any energy efficiency and fuel switching measures implemented at a single or several industrial or mining and mineral production facility(ies). This category covers project activities aimed primarily</i></p>	<p>The technology for GHG emission reduction is an energy efficiency improvement measure for a steel furnace on a single industrial production facility. This project activity is to be carried out at a single industrial production facility of</p>

CDM – Executive Board

<p><i>at energy efficiency; a project activity that involves primarily fuel switching falls into category III.B.¹ Examples include energy efficiency measures (such as efficient motors), fuel switching measures (such as switching from steam or compressed air to electricity) and efficiency measures for specific industrial or mining and mineral production processes (such as steel furnaces, paper drying, tobacco curing, etc.).</i></p>	<p>Davsteel, the steel manufacturing division of the Cape Gate (Pty) Ltd group.</p> <p>This is an energy efficiency measure on a steel furnace that does not involve any fuel switching.</p>
<p>2. <i>The measures may replace, modify or retrofit existing facilities or be installed in a new facility.</i></p>	<p>The measure is a modification of the existing facility.</p>
<p>3. <i>This category is applicable to project activities where it is possible to directly measure and record the energy use within the project boundary (e.g., electricity and/or fossil fuel consumption).</i></p>	<p>The energy use (electricity consumption) is directly measured and recorded on site with metering equipment within the project boundary.</p>
<p>4. <i>This category is applicable to project activities where the impact of the measures implemented (improvements in energy efficiency) by the project activity can be clearly distinguished from changes in energy use due to other variables not influenced by the project activity (signal to noise ratio).</i></p>	<p>As described in section A.4.2, the project activity involves the modification to the existing operation. The project results in an energy saving measured in kWh/ton, which can be directly measured on site by independently measuring the steel production and energy consumption of the process. The impact of implementation is clearly distinguished and measurable.</p>
<p>5. <i>The aggregate energy savings of a single project (inclusive of a single facility or several facilities) may not exceed the equivalent of 60 GWh_e per year. A total saving of 60 GWh_e per year is equivalent to a maximal saving of 180 GWh_{th} per year in fuel input.</i></p>	<p>The aggregate energy savings of the project is estimated to be significantly below the 60 GWh_e per year limit. In section B.6.3 it is calculated that the annual saving are 30,066 ton CO₂e, which is equivalent to 29 GWh_e. This is significantly below the upper value of 60 GWh_e.</p>

Methodology AMS-II.D (version 12.0) is therefore applicable to the project activity.

B.3. Description of the project boundary:

>>

As per the AMS-II.D “The project boundary is the physical, geographical site of the industrial or mining and mineral production facility, processes or equipment that is affected by the project activity.”

¹ Thus, fuel switching measures that are part of a package of energy efficiency measures at a single location may be part of a project activity included in this project category.

In accordance with the guidance of the approved small scale methodology, the project boundary will therefore include the meltshop facility at the Davsteel site in Vanderbijlpark. The project boundary is illustrated in Figure 2.

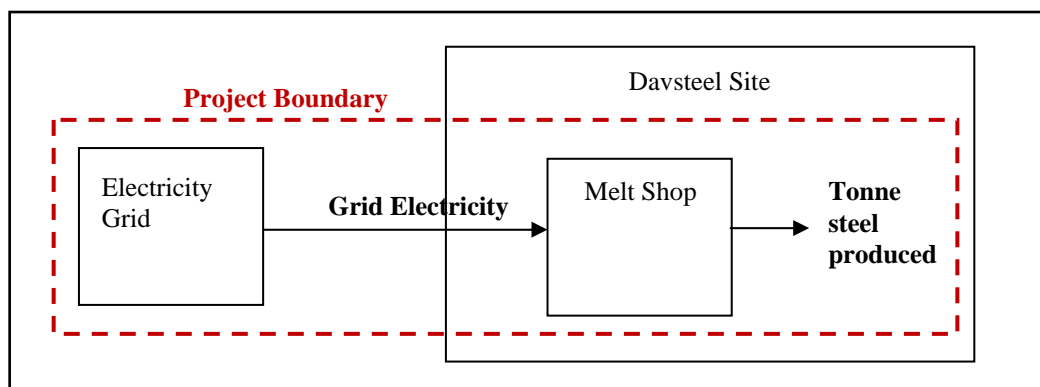

Figure 2: Project Boundary

B.4. Description of baseline and its development:

>>

According to the approved small scale methodology AMS-II.D (paragraph 7) “*In the case of replacement, modification or retrofit measures, the baseline consists of the energy baseline of the existing facility or sub-system that is replaced, modified or retrofitted.*” As the project activity is modification of an existing facility, the energy baseline scenario in absence of the project activity would be the pre- project practice i.e. steel making in the EAF using arcing to produce desired quality of steel, which had greater electricity consumption per ton of steel production.

Although this project activity is a modification/retrofit to an existing facility, the modification/retrofit to the EAF results in a higher productivity of the steel production process, and thus a capacity increase of the Davsteel meltshop.

According to paragraph 8 of the methodology, “*For new facilities and project activities involving capacity additions, the energy baseline consist of the facility that would otherwise be built; the most plausible baseline scenario for the project activity shall be evaluated based on the related and relevant requirements in the General Guidelines to SSC CDM methodologies.*”

The “*General Guidelines to SSC CDM methodologies*” (version 17) state in paragraph 20: “*For project activities that seek to retrofit the baseline may refer to the characteristics (i.e. emissions) of the existing unit or equipment **only to the extent that the project activity does not increase capacity or output** or level of service unless detailed specifications are provided as part of the indicated methodology. For any increase of capacity or output or level of service beyond this range, which is due to the project activity, a different baseline shall apply.*”

Due to the above mentioned, for the new production capacity, the most plausible baseline scenario will be determined by the assessment of alternatives to the project activity as set forth in paragraphs 19 and 21 of the “*General Guidelines to SSC CDM methodologies*” (version 17).

Assessment of alternative scenarios:

 CDM – Executive Board

Step 1: Identify alternative scenarios available to the project proponent that deliver comparable level of service

There are few realistic and credible alternatives available to the project participants or similar project developers that provide outputs or services comparable to the proposed CDM project activity; alternative scenarios identified include:

- (a) The proposed project activity undertaken without being registered as a CDM project activity;
- (b) A capacity upgrade of the currently installed EAF to utilise existing technology;

Step 2: Is alternative compliant with local regulations?

Both alternatives (a) and (b) are compliant with all laws and regulations in South Africa. There is a policy that exist which support energy efficiency technology, but this is not a mandatory policy.

Step 3: Barrier analysis in accordance with attachment A to Appendix B of the simplified modalities and procedures of SSC CDM

- **Barrier due to prevailing practice:** The Consteel process, as in the project activity, is an innovative melting technology and the installation at Cape Gate is the first in South Africa (Memoli & Ferri, 2008). The project activity is therefore first-of-its-kind.
- **Technological barrier:** The Consteel process, as in the project activity, is the only commercial technology that is able to continuously feed and preheat the metallic charge to EAF while keeping the gaseous emissions under control, without additional energy consumption (Fanutti & Pozzi, 2004). Experience in the field of operating and managing these systems are therefore scarce, especially in South Africa (Memoli & Ferri, 2008). Since Cape Gate has no exposure to a similar type of activity, the failure of the system may result in the operational disturbance and subsequent shutdown of the plant and all downstream processes resulting in heavy financial losses. The additional incentive in terms of potential GHG reduction has enabled Cape Gate to receive management approval for the project activity in-spite of anticipated technological barriers associated with the project activity.

Both of the abovementioned barriers are barriers to alternative scenario (a).

Step 4: Identification of most probable alternative scenario

Only one alternative scenario remains, which is alternative (b), a capacity upgrade of the currently installed EAF to utilise existing technology. This will therefore be considered the baseline for the capacity upgrade. The historical operational parameters of the existing facility will be used as the baseline parameters for the capacity increase.

As a result of the assessment of alternatives to the project activity, as conducted above, the baseline for the project activity will be on the existing meltshop facility, prior to the project activity, but at an increased capacity similar to that of the project activity. The historical recorded electricity consumption and steel production figures of the currently installed EAF will be used to determine the energy efficiency, which will in turn be used together with the production capacity of the project activity to determine the new baseline.

“In order to estimate the point in time when the existing equipment would need to be replaced in the absence of the project activity ($DATE_{BaselineRetrofit}$), project participants may follow the procedures

CDM – Executive Board

described in the general guidance”. The “Tool to determine the remaining lifetime of equipment” (version 01) was used, as referred to by the guidance.

The remaining lifetime of the equipment was determined by obtaining an expert evaluation from Tenova (see the letter dated 15 Nov 2011). The existing EAF were commissioned in 1980, and has a lifetime for as long as Cape Gate is maintaining all the equipment. There is no plan of replacement during the project activity lifetime.

Table 1: Data parameters for calculation of project activity baseline

Baseline Information				
Parameter	Notation	Unit	Value	Remark
Average historical quantity of steel produced by the Meltshop	Q_{avg}	Ton/year	458,144	Calculated from average of 3 years production figures.
Average historical electricity consumption for the Meltshop	EC_{avg}	MWh/year	297,631	Calculated from average of 3 years electricity consumption figures.
Average historical electricity efficiency for the Meltshop	EE_{BL}	MWh/ton	0.650	Calculated using 3 year average data
Emission Factor for grid electricity	EF_{grid}	Ton CO ₂ e/MWh	1.028	As calculated with the CDM tool. (See Section B.6)

B.5. Description of how the anthropogenic emissions of GHG by sources are reduced below those that would have occurred in the absence of the registered small-scale CDM project activity:

In accordance with paragraph 28 of the “Simplified Modalities and Procedures for Small-Scale CDM project activities”, a simplified baseline and monitoring methodology listed in “Appendix B” may be used if project participants can demonstrate that the project activity would otherwise not be implemented due to the existence of one or more barrier(s) listed in “Attachment A” of “Appendix B”: (a) Investment barrier, (b) Technological barrier, (c) Barrier due to prevailing practice, (d) Other barriers.

In absence of the project activity the project proponent would have continued with the pre-project practice i.e. use of the currently installed EAF without the energy efficiency improving Consteel modification, leading to electricity consumption at the historical level. This is the most commonly followed practice in Iron and Steel Sector in South Africa so far as steel making via the EAF route is concerned; The Cape Gate Consteel installation is the first in South Africa (Memoli & Ferri, 2008).

Barrier due to prevailing practice:

“Prevailing practice or existing regulatory or policy requirements would have led to implementation of a technology with higher emissions;”

According to EB 63 Annex 11: “Guidelines on additionality of first-of-its-kind project activities” (Version 01.0), a proposed project activity is the First-of-its-kind in the applicable geographical area if:

- (a) *The project is the first in the applicable geographical area that applies a technology that is different from any other technologies able to deliver the same output and that*

CDM – Executive Board

- have started commercial operation in the applicable geographical area before the start date of the project; and*
- (b) *Project participants selected a crediting period for the project activity that is “a maximum of 10 years with no option of renewal”.*

The Consteel process, as in the project activity, is an innovative melting technology and the installation at Cape Gate is the first in South Africa (which is the “applicable geographical area”) (Memoli & Ferri, 2008). The project activity is therefore additional as a first-of-its-kind project activity.

A similar Consteel project has been registered under the CDM as a Joint Implementation project: “Reconstruction of the steelmaking at JSC “Ashinskiy Metallurgical Works”, Asha, Russian Federation (17/01/2011)”. Various other projects utilising a similar furnace feed pre-heating system has also been registered under the CDM.

CDM Consideration

The project activity was approved by the Board of Directors of Cape Gate after considering that the project activity would reduce GHG emissions and therefore could have the potential to avail carbon revenue under Kyoto Protocol – Clean Development Mechanism. Subsequent to the approval, the Management has proceeded with the implementation of the project activity as a climate change initiative.

This project activity has a start date of 24 April 2008. The board decision on 6 Dec 2007, together with the email communication between Geoff Holmes and consultants detailing carbon credit consideration (30 Jan 2008 – 23 Jul 2008), indicates awareness of the CDM prior to the project activity start date, and that the benefits of the CDM were a decisive factor in the decision.

Table 2 gives the chronological events related to the project activity. In this table the CDM-related events are highlighted in grey, and shows that real and continuing actions were taken with documented evidence substantiating these actions.

Table 2: Documentation and decisions relating the Consteel process and project activity to CDM

Date	Project Activity Key Events
6 Dec 2007	Board decision on Davsteel expansion made. (supporting documentation: “Board decision, 2007-12-11”) <i>“Not only will this technology increase production volumes, but it will reduce energy and electrode costs and will be more environmental friendly than the current process”.</i> The board decision is based on the reduction of energy consumption from the high GHG South African grid as well as the reduction of carbon used in the electrodes that convert to CO ₂ in the furnace off gas. (Other supporting documentation considered in decision-making process: (Arreaza, 2003) (Kumar, 2005) (The Energy and Resources Institute, 2006) (International Energy Agency, 2007))
13 Dec 2007	Cape Gate signed Scope of Supply Agreement for Techint S.p.A. (supporting documentation: “Techint S.p.A., 2007”)
30 Jan 2008 – 23 Jul 2008	Email communication between Geoff Holmes and consultants detailing carbon credit consideration (supporting documentation: “prior consideration”).
19-21 Feb 2008	Meeting between Cape Gate and Tenova to discuss “Scope of Supply and Agreement” (Tenova, 2008)

CDM – Executive Board

24 April 2008	Starting date of project activity: First 10% down payment made by Cape Gate to Tenova (supporting documentation not provided due to confidentiality)
29 May 2008	Board decision to cancel bar mill expansion program (supporting documentation: “Board decision, 2008-05-29”)
21 July 2008	Second 10% down payment made by Cape Gate to Tenova (supporting documentation not provided due to confidentiality)
28 Jul 2008	Email from Geoff Holmes confirming that carbon credit work is in progress by a carbon credit consultant (supporting documentation: “prior consideration”).
Oct 2008	Basic assessment report conducted for installation of Consteel process (supporting documentation: “Basic Assessment Report - Cape Gate Consteel - October 2008”).
Dec 2009 – Jan 2010	Installation of Consteel technology at Davsteel, and project activity commissioning (Tenova, 2008).
19 March 2010	Email communication between Promethium Carbon, Edward Nathan Sonnenbergs, and Cape Gate regarding preparation of a quote by Promethium Carbon to do the carbon consulting work in order to register the project as a CDM project (supporting documentation: “2010-12 - RTL emails -Cape Gate”).
14 March 2011	Letter of engagement signed by Nedbank for the carbon consulting work to be done by Promethium Carbon (supporting documentation: “Letter of Engagement”).
30 September 2011	Start of GSP process

B.6. Emission reductions:**B.6.1. Explanation of methodological choices:**

>>

The formula to calculate the project’s emission reductions are:

$$ER_y = BE_y - PE_y - LE_y \quad (1)$$

Where:

ER_y Emission reduction in ton CO₂e in year y
 BE_y Baseline emissions in ton of CO₂e in year y
 PE_y Project emissions in ton of CO₂e in year y
 LE_y Leakage in ton of CO₂e in year y

Baseline Emissions (BE_y)

The definition of the baseline is outlined in section B.4 of the PDD.

$$EE_{BL} = EC_{avg} \div Q_{avg} \quad (2)$$

Where:

EC_{avg} Average historical electricity consumption for the Meltshop (MWh/year)
 Q_{avg} Average historical quantity of steel produced by the Meltshop (ton/year)
 EE_{BL} Average historical electricity efficiency for the Meltshop (MWh/ton)

With the slight deviations in steel production figures from one year to the next, the electricity consumption in the baseline needs to be continuously adjusted with the fixed energy efficiency (EE_{BL})

CDM – Executive Board

to avoid having emission reductions merely as a result of reduced steel production in future below the current baseline.

Therefore:

$$BE_y = EE_{BL} \times Q_y \times EF_{grid} \quad (3)$$

Where:

Q_y Annual steel production for the project activity in year y (ton/year).
 EF_{grid} Emission factor for grid electricity (ton CO₂e/MWh)

The emission factor for the grid electricity was calculated in accordance with the latest approved version of the “Tool for calculation of emission factor for electricity systems,” Version 02.2.0. The steps applied to determine the emission factor for the grid can be seen in Annex 3.

Project Emissions (PE_y)

The energy efficiency for the project activity must be calculated using the measured steel production and the associated electricity consumption of the Meltshop:

$$EE_y = EC_y \div Q_y \quad (4)$$

Where:

EC_y Project activity electricity consumption for the Meltshop in year y (MWh/year)
 Q_y Steel produced by the Meltshop in year y of the project activity (ton/year)
 EE_y Electricity efficiency for the Meltshop in year y of the project activity (MWh/ton)

Using the calculated electricity efficiency for the project activity, the project emissions can be calculated as follows:

$$PE_y = EE_y \times Q_y \times EF_{grid} \quad (5)$$

Where:

EF_{grid} Emission factor for grid electricity (ton CO₂e/MWh)

Leakage Emissions (LE_y)

There is no transfer of equipment currently being utilised, from outside the boundary to the project activity, therefore there is no leakage emissions.

$$LE_y = 0$$

B.6.2. Data and parameters that are available at validation:

Data / Parameter:	Q_{avg}
Data unit:	Ton/year
Description:	Average historical quantity of steel produced by the Meltshop (billet production)

CDM – Executive Board

Source of data used:	Plant records.
Value applied:	458,144
Justification of the choice of data or description of measurement methods and procedures actually applied :	Calculated from average of latest 3 years production figures as supplied by Cape Gate. Actual production values as measured and recorded by the Meltshop.
Any comment:	

Data / Parameter:	EC_{avg}
Data unit:	Average historical electricity consumption for the Meltshop
Description:	MWh/year
Source of data used:	Plant records
Value applied:	297,631
Justification of the choice of data or description of measurement methods and procedures actually applied :	Electricity consumption figures as reflected on monthly electricity bills of the Meltshop are recorder in the plant records. The 3 year average consumption figures, prior to project activity implementation, are used.
Any comment:	

Data / Parameter:	EE_{BL}
Data unit:	MWh/Ton
Description:	Average historical electricity efficiency for the Meltshop.
Source of data used:	Calculated from Meltshop electricity consumption and steel production figures.
Value applied:	0.650
Justification of the choice of data or description of measurement methods and procedures actually applied :	Q_{avg} and EC_{avg} are used to calculate a fixed baseline energy efficiency of the Meltshop.
Any comment:	

Data / Parameter:	EF_{grid}
Data unit:	Ton CO ₂ e/MWh
Description:	Emission Factor for grid electricity
Source of data used:	Eskom annual reports and dedicated CDM data
Value applied:	1.028
Justification of the choice of data or description of measurement methods and procedures actually applied :	As calculated with the CDM tool. (See Annex 3)
Any comment:	

CDM – Executive Board

Data / Parameter:	EE _y
Data unit:	MWh/Ton
Description:	Average electricity efficiency for the Meltshop in year y of the project activity.
Source of data used:	Calculated from year y electricity consumption and steel production.
Value applied:	0.598
Justification of the choice of data or description of measurement methods and procedures actually applied :	This value is an initial value and only calculated from data for the months of August to October 2011 due to reasons provided to the validators. This value will be recalculated and updated on an annual basis based on the project activity data.
Any comment:	

B.6.3 Ex-ante calculation of emission reductions:

>>

The ex-ante calculations for each year of the crediting period are the same; therefore emission reduction calculations will only be illustrated for the first year (y=1), and not for the entire 10 year crediting period from 2012-2021.

Equation 2:

$$EE_{BL} = EC_{avg} \div Q_{avg} = 297,631 \div 458,144 = 0.650 \text{ MWh/ton}$$

Equation 3:

$$BE_y = EE_{BL} \times Q_y \times EF_{grid} = 0.650 \times 570,555 \times 1.028 = 381,037 \text{ ton CO}_2\text{e}$$

Equation 4:

$$EE_y = EC_y \div Q_y = 341,411 \div 570,555 = 0.598 \text{ MWh/ton}$$

Equation 5:

$$PE_y = EE_y \times Q_y \times EF_{grid} = 0.598 \times 570,555 \times 1.028 = 350,970 \text{ ton CO}_2\text{e}$$

Equation 1:

$$ER_1 = BE_1 - PE_1 - LE_1 = 376,959 - 347,215 - 0 = 30,066 \text{ ton CO}_2\text{e}$$

Crediting Period	ER _y (ton CO ₂ e)
1	30,066
2	30,066
3	30,066
4	30,066
5	30,066
6	30,066
7	30,066
8	30,066
9	30,066
10	30,066

CDM – Executive Board

B.6.4 Summary of the ex-ante estimation of emission reductions:

>>

Year	Estimation of project activity emissions (ton CO ₂ e)	Estimation of baseline emissions (ton CO ₂ e)	Estimation of leakage (ton CO ₂ e)	Annual estimation of emission reductions (ton CO ₂ e)
1	350,970	381,037	0	30,066
2	350,970	381,037	0	30,066
3	350,970	381,037	0	30,066
4	350,970	381,037	0	30,066
5	350,970	381,037	0	30,066
6	350,970	381,037	0	30,066
7	350,970	381,037	0	30,066
8	350,970	381,037	0	30,066
9	350,970	381,037	0	30,066
10	350,970	381,037	0	30,066
Total (ton CO₂e)	3,509,700	3,810,370	0	300,660

B.7 Application of a monitoring methodology and description of the monitoring plan:

The following two sections (B.7.1 & B.7.2) provides a detailed description of the application of the monitoring methodology and description of the monitoring plan, including identification of the data to be monitored and the procedures that will be applied during monitoring.

B.7.1 Data and parameters monitored:

Data / Parameter:	Q _v
Data unit:	Ton/year
Description:	Annual steel production for the project activity
Source of data to be used:	Plant records
Value of data	570,555
Description of measurement methods and procedures to be applied:	Monitoring Procedure: Billet production is the output of the Meltshop (i.e. steel produced) and are weighed automatically on non-assized scales once they exit the Meltshop and enters the Rolling Mills re-heat furnaces. Data Type: Measured Archiving Procedure: Electronic Recording Frequency: Measured per cast sequence to the re-heat furnaces, logged onto Mills Morning Meeting Report, and collated monthly and annually Responsibility: Operator on duty.
QA/QC procedures to be applied:	The weighing scales are calibrated during each shift, as per industry standards, with test weights available on site. This is done by the operator on duty and also logged onto the Mills Morning Meeting Report.
Any comment:	Actual production values as measured and recorded by the Meltshop. This value is an initial value and only for the month of August 2011 due to reasons provided to the validators.

CDM – Executive Board

Data / Parameter:	EC _y
Data unit:	MWh/year
Description:	Electricity consumption per year for project activity
Source of data to be used:	Plant records
Value of data	341,411
Description of measurement methods and procedures to be applied:	Monitoring Procedure: Electricity meters for the Meltshop are consolidated to yield an overall Meltshop total. Data Type: Measured Archiving Procedure: Electronic Recording Frequency: Logged each 30mins, summarized monthly and annually Responsibility: logged automatically onto electronic database and collated by Master Technician.
QA/QC procedures to be applied:	Electrical meters are replaced immediately once errors occur; no calibration is done. The data is correlated with the monthly Municipal account, using the internal metering system to allocate costs to the relevant internal production departments.
Any comment:	Electricity consumption figures as reflected on monthly electricity bills of the Meltshop are recorder in the plant records. This value is an initial value and only for the month of August 2011 due to reasons provided to the validators.

Data / Parameter:	EE _y
Data unit:	MWh/Ton
Description:	Average electricity efficiency for the Meltshop in year y of the project activity.
Source of data to be used:	Calculated from year y electricity consumption and steel production.
Value of data	0.598
Description of measurement methods and procedures to be applied:	This is a calculated value from year y electricity consumption and steel production by the Master Technician.
QA/QC procedures to be applied:	
Any comment:	This value is an initial value and only calculated from data for the months of August to October 2011 due to reasons provided to the validators. This value will be recalculated and updated on an annual basis based on the project activity data.

In case of any replacement/modification/addition of equipments pertaining to the project activity, records will be maintained duly signed by the plant head.

B.7.2 Description of the monitoring plan:

>>

Equipment for monitoring the electricity consumption of the entire Meltshop and steel production (recorded as billet production leaving the Meltshop) is installed at the existing facility.

The Meltshop total electrical consumption is the summation of meters 5,6,17 & 20, as illustrated in Figure 6. The meters record the data automatically on 30min intervals. The data is stored electronically (logged onto computer), and collated monthly and annually basis by the Master Technician in order to obtain the total electricity consumption for the Meltshop.

CDM – Executive Board

The meters are electronic and no form of calibration is taking place. Meters are only replaced once errors occur or faulty values are shown. Errors and incorrect values become apparent at month-end collation of data, where the metered data is compared to other meters on site (L&G meters displayed in Figure 6) and municipality electricity bills.

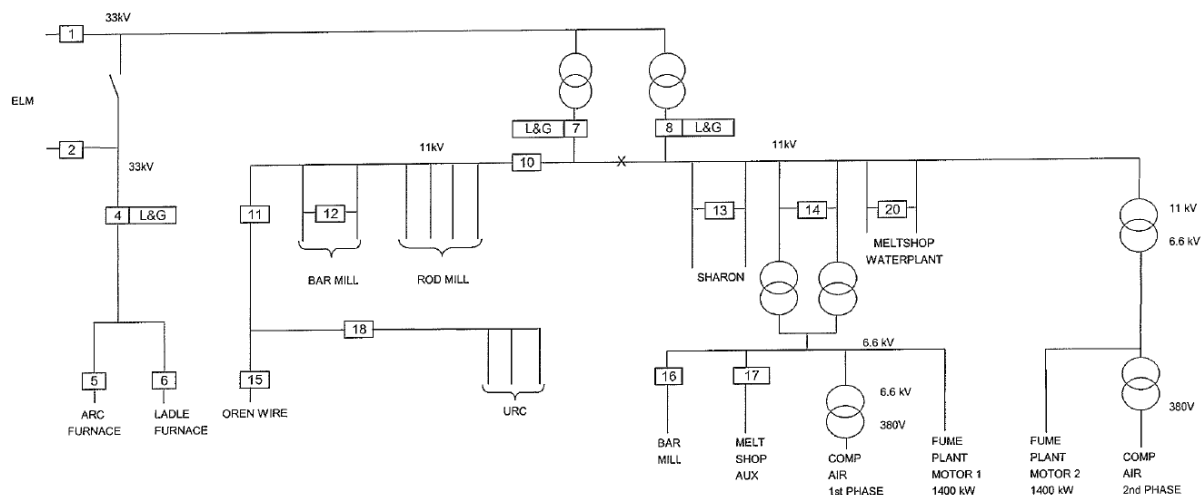

Figure 6: Cape Gate electricity metering lay-out 2011

The billets produced in the Meltshop are sent to the Rolling Mills where it is weighed on scales before entering the re-heating furnaces. It is the duty of the operator on duty to weigh the billets. All the data is recorder electronically, and collated monthly and annually by the technical operator. The scales are calibrated during each shift with test weights that is kept on site.

Data monitored and required for verification and issuance of carbon credits are to be kept for two years after the end of crediting period or the last issuance of CERs for this project activity, whichever occurs later.

B.8 Date of completion of the application of the baseline and monitoring methodology and the name of the responsible person(s)/entity(ies)

>>

The application of the baseline study and monitoring methodology was completed on 31 August 2011.

Promethium Carbon (Pty) Ltd.
P O Box 131253
Bryanston
2021
South Africa

Promethium Carbon (Pty) Ltd. is not a Project Participant.

CDM – Executive Board

SECTION C. Duration of the project activity / crediting period

C.1 Duration of the project activity:

C.1.1. Starting date of the project activity:

>>

24/04/2008

C.1.2. Expected operational lifetime of the project activity:

>>

The remaining lifetime of the equipment was determined by obtaining an expert evaluation from Tenova (see the letter dated 15 Nov 2011). The existing EAF were commissioned in 1980, and has a lifetime for as long as Cape Gate is maintaining all the equipment. The installed equipment in this project activity is therefore expected to last for as long as all equipment is maintained. Maintenance records of the equipment are up to date, and therefore the lifetime of the equipment is infinite.

C.2 Choice of the crediting period and related information:

C.2.1. Renewable crediting period

C.2.1.1. Starting date of the first crediting period:

>>

C.2.1.2. Length of the first crediting period:

>>

C.2.2. Fixed crediting period:

C.2.2.1. Starting date:

>>

01/01/2012, or the date of registration, if it is after this date

C.2.2.2. Length:

>>

10 years 0 months

SECTION D. Environmental impacts

>>

D.1. If required by the host Party, documentation on the analysis of the environmental impacts of the project activity:

>>

No EIA is required for the Consteel process. However, the Consteel adaptation allows for an increase in production capacity of steel and therefore the Basic Assessment process is being followed for the increase in production capacity.

As stated in the Basic Assessment Report compiled for this project, The National Environmental Management Act, 107 of 1998 and the associated EIA Regulations are the principle pieces of legislation which must be examined when determining what the authorisation is that Cape Gate needs

CDM – Executive Board

to proceed with for this project. Item 25 of the GNR 386 states that “*The expansion of or changes to existing facilities for any process or activity which requires an amendment of an existing permit or licence or a new permit or licence in terms of legislation governing release of emissions, pollution, effluent*” requires a basic assessment to be carried out.

Other associated environmental impacts have been carefully evaluated and there are no environmental impacts which trigger any of the other listed activities under either GNR 386 or GNR 387.

A Basic Assessment Report (BAR) was compiled by Mills and Otten; independent environmental consultants. The report covers the necessary details for the modification of the Electric Arc Furnace at the Davsteel division of Cape Gate (Pty) Ltd. The Consteel project is a variation on the traditional electric arc furnace in that there are great benefits to the environment.

The Consteel process is considered an environmentally favourable operation as the benefits of the process is that the scrap steel and additives are added into the furnace by means of a covered conveyor belt. This process does not require the lid of the furnace to be opened, the time during which most emissions are released. The emissions are therefore greatly reduced as well as benefits in terms of electricity consumption and demand. Of importance is the reduction in fugitive emissions from the operation. The off-gases are fed up the conveyor belt which ensures that the scrap feed is “pre-heated” and that the dust emissions are deposited on the scrap and fed back into the furnace. This results in reduced dust emissions and reduced off-gasses.

The BAR states in the “Environmental Impact Statement” that: “*The proposed increase in production of steel at the Davsteel Meltshop is urgently required to meet demand for steel in South Africa. The Consteel method of feeding scrap metal into the EAF will minimise any impacts to the point where they are not considered significant. The impacts associated with the operational phase are generally positive and the negative impacts can be suitably mitigated.*”

D.2. If environmental impacts are considered significant by the project participants or the host Party, please provide conclusions and all references to support documentation of an environmental impact assessment undertaken in accordance with the procedures as required by the host Party:

>>

The Basic Assessment Report (BAR) compiled by Mills and Otten conclude in the impact summary that: “*The proposed increased production of steel using the Consteel process will allow additional steel to be produced at an existing facility with no associated impact on air quality within the Vaal Triangle Priority Airshed area.*”

The project activity is one of the commitments of Cape Gate management to ensure sustainable development of the region. The impact assessment, as explained above, clearly establishes that the project activity will have no major negative impact on the baseline environment.

SECTION E. Stakeholders’ comments

>>

E.1. Brief description how comments by local stakeholders have been invited and compiled:

>>

Two news articles (in English and Afrikaans) have been published in the local news papers, the Vaal Weekly, which was selling in the week of 14-20 September 2011. The articles stated that the project

CDM – Executive Board

will be considered for carbon credits. Comments were invited by local stakeholders up to 30 September 2011.

E.2. Summary of the comments received:

>>

No comments were received.

E.3. Report on how due account was taken of any comments received:

>>

No comments were received, therefore there was no need for any action on comments.

 CDM – Executive Board
Annex 1**CONTACT INFORMATION ON PARTICIPANTS IN THE PROJECT ACTIVITY**

Organization:	Cape Gate (Pty) Ltd
Street/P.O.Box:	3 Nobel Blvd / P.O. Box 54
Building:	
City:	Vanderbijlpark
State/Region:	Gauteng
Postfix/ZIP:	1900
Country:	South Africa
Telephone:	+27 16 980 2121
FAX:	
E-Mail:	info@capegate.co.za
URL:	http://www.capegate.co.za/
Represented by:	
Title:	Mr
Salutation:	
Last Name:	Holmes
Middle Name:	
First Name:	Geoff
Department:	
Mobile:	+27 82 807 0706
Direct FAX:	
Direct tel:	+27 16 980 2342
Personal E-Mail:	HolmesG@capegate.co.za

Annex 2

INFORMATION REGARDING PUBLIC FUNDING

Annex 3

BASELINE INFORMATION

GRID EMISSION FACTOR CALCULATIONS

STEP 1: IDENTIFY THE RELEVANT ELECTRICITY SYSTEMS

This tool will serve project activities that prospect to displace grid electricity in South Africa. The **project electricity system** is defined by the spatial extent of the power plants that are physically connected through transmission and distribution lines to the project activity and that can be displaced without significant transmission constraints.

Similarly, a **connected electricity system**, e.g. national or international, is defined as an electricity system that is connected by transmission lines to the project electricity system. Power plants within the connected electricity system can be dispatched without significant transmission constraints, but transmission to the project electricity system has significant transmission constraints.

The DNA of South Africa has not published a delineation of the project electricity system and connected electricity systems, therefore the following was chosen for this project:

- The grid boundary is chosen as the South African national grid boundary. The **project electricity system** entails all the Eskom power plants in the South African electricity grid.
- Due to a lack of data available in the public domain (in order to evaluate significant transmission constraints), all countries in the Southern African Power Pool (SAPP) are conservatively treated as **connected electricity systems**, and emission factors for imports from these countries are assumed to be 0 tCO₂/MWh.

All electricity generated by the Eskom power stations is taken into consideration when calculating the grid emission factor; exports are not subtracted.

All the data for the Eskom power stations are obtained from the Eskom website, where they have a specific webpage dedicated to CDM grid emission factor related data (Eskom Holdings SOC Limited, 2011). This data includes commissioning dates, electricity generated, and fuel consumed.

Data for the imported electricity are obtained from the Eskom annual report, where “*Total purchased for the Eskom system (GWh)*” is shown in the “*Statistical overview*” table on pg. 324 of the report (Eskom Holdings SOC Limited, 2011).

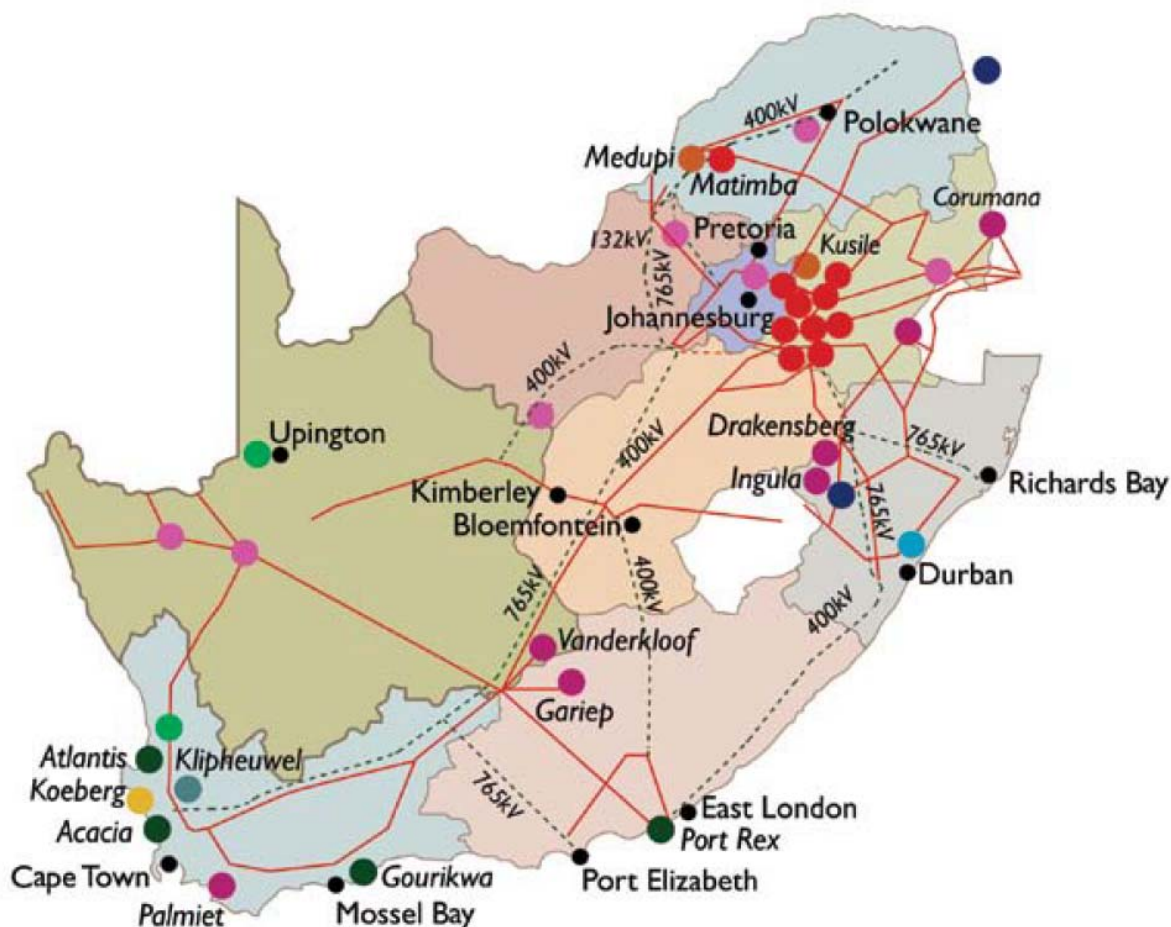

STEP 2: CHOSE WHETHER TO INCLUDE OFF-GRID POWER PLANTS IN THE PROJECT ELECTRICITY SYSTEM

This step is optional according to the tool. The grid emission factor is calculated from only grid power plants (**Option I**). Off-grid power plants are not included in the calculations.

STEP 3: SELECT A METHOD TO DETERMINE THE OPERATING MARGIN (OM)

The OM is calculated using the **simple OM method (Option a)**. The simple OM method can be used provided that the low-cost/must-run resources constitute less than 50% of the total grid generation in average of the five most recent years.

The average percentage of low-cost/must-run resources amount to 0.00% of the total grid generation for this project electricity system. Therefore, Option (a) is applicable.

In terms of data vintages, the *ex ante* option were chosen to calculate the simple OM. In this option a 3 year generation-weighted average are used for the grid power plants. Using this option also means that the emission factor is determined only once at the validation stage, thus no monitoring and recalculation is required during the crediting period.

CDM – Executive Board

The data used in OM calculations are for the 3 year period of 1 April 2008 – 31 March 2011 (Eskom financial year runs from 1 April – 31 March). This is the latest available data.

STEP 4: CALCULATE THE OPERATING MARGIN EMISSION FACTOR ACCORDING TO THE SELECTED METHOD

The simple OM emission factor ($EF_{grid,OMsimple,y}$) is calculated as the generation-weighted average CO₂ emissions per unit net electricity generation (tCO₂/MWh) of all generating power plants serving the system, not including low-cost/must-run power plants/units. Hence, the hydro and nuclear power plants are excluded from the calculation of the OM.

Option A is used for calculating the simple OM. The calculations in this option are based on the total net electricity generation and a CO₂ emission factor of each power plant.

Option A – Calculation based on average efficiency and electricity generation of each plant

Under this option, the simple OM emission factor is calculated based on the net electricity generation of each power plant and an emission factor of each power plant, as follows:

$$EF_{grid,OMsimple,y} = \frac{\sum_m EG_{m,y} \times EF_{EL,m,y}}{\sum_m EG_{m,y}}$$

Where:

$EF_{grid,OMsimple,y}$	= Simple operating margin CO ₂ emission factor in year y (tCO ₂ /MWh)
$EG_{m,y}$	= Net quantity of electricity generated and delivered to the grid by power unit m in the year y (MWh)
$EF_{EL,m,y}$	= CO ₂ emission factor of power unit m in year y (tCO ₂ /MWh)
m	= All power units serving the grid in year y except low-cost/must-run power units
y	= The relevant year as per data vintage chosen in Step 3

Determination of $EF_{EL,m,y}$

The emission factor for each power plant m were determined as follows (**Option A1**):

$$EF_{grid,OMsimple,y} = \frac{\sum_i (FC_{i,y} \times NCV_{i,y} \times EF_{CO_2,i,y})}{EG_y} \quad (6)$$

Where:

$EF_{grid,OMsimple,y}$	= Simple operating margin CO ₂ emission factor in year y (tCO ₂ /MWh)
$FC_{i,y}$	= Amount of fossil fuel type i consumed in the project electricity system in year y (mass or volume unit)

CDM – Executive Board

$NCV_{i,y}$	=	Net calorific value (energy content) fossil fuel type i in year y (GJ/mass or volume unit)
$EF_{CO_2,i,y}$	=	CO ₂ emission factor of fossil fuel type i in year y (tCO ₂ /GJ)
EG_y	=	Net electricity generated and delivered to the grid by all power sources serving the system, not including low-cost/must-run power plants/units, in year y (MWh)
i	=	All fossil fuel types combusted in power sources in the project electricity system in year y
y	=	The relevant year as per data vintage chosen in Step 3.

Electricity imports are treated as one power plant, as per the tool guidance.

The constants used in calculations appear in Table 1.

Table 1: Constants used in calculations

Constants		
$NCV_{\text{other bituminous coal}}$	19.9	GJ/T
$NCV_{\text{other kerosene}}$	42.9	GJ/T
$EF_{CO_2\text{other bituminous coal}}$	0.0895	tCO ₂ /GJ
$EF_{CO_2,\text{other kerosene}}$	0.0708	tCO ₂ /GJ

Using equation 6, the OM is calculated as **1.0182** tCO₂e/MWh.

STEP 5: CALCULATE THE BUILD MARGIN (BM) EMISSION FACTOR

In terms of vintage of data, one **Option 1** was selected: For the first crediting period, calculate the build margin emission factor *ex ante* based on the most recent information available on units already built for sample group m at the time of CDM-PDD submission to the DOE for validation.

The sample group of power units m used to calculate the build margin were determined as per the procedure delineated in the tool, consistent with the data vintages selected.

The following diagram summarizes the procedure of identifying the sample group:

CDM – Executive Board

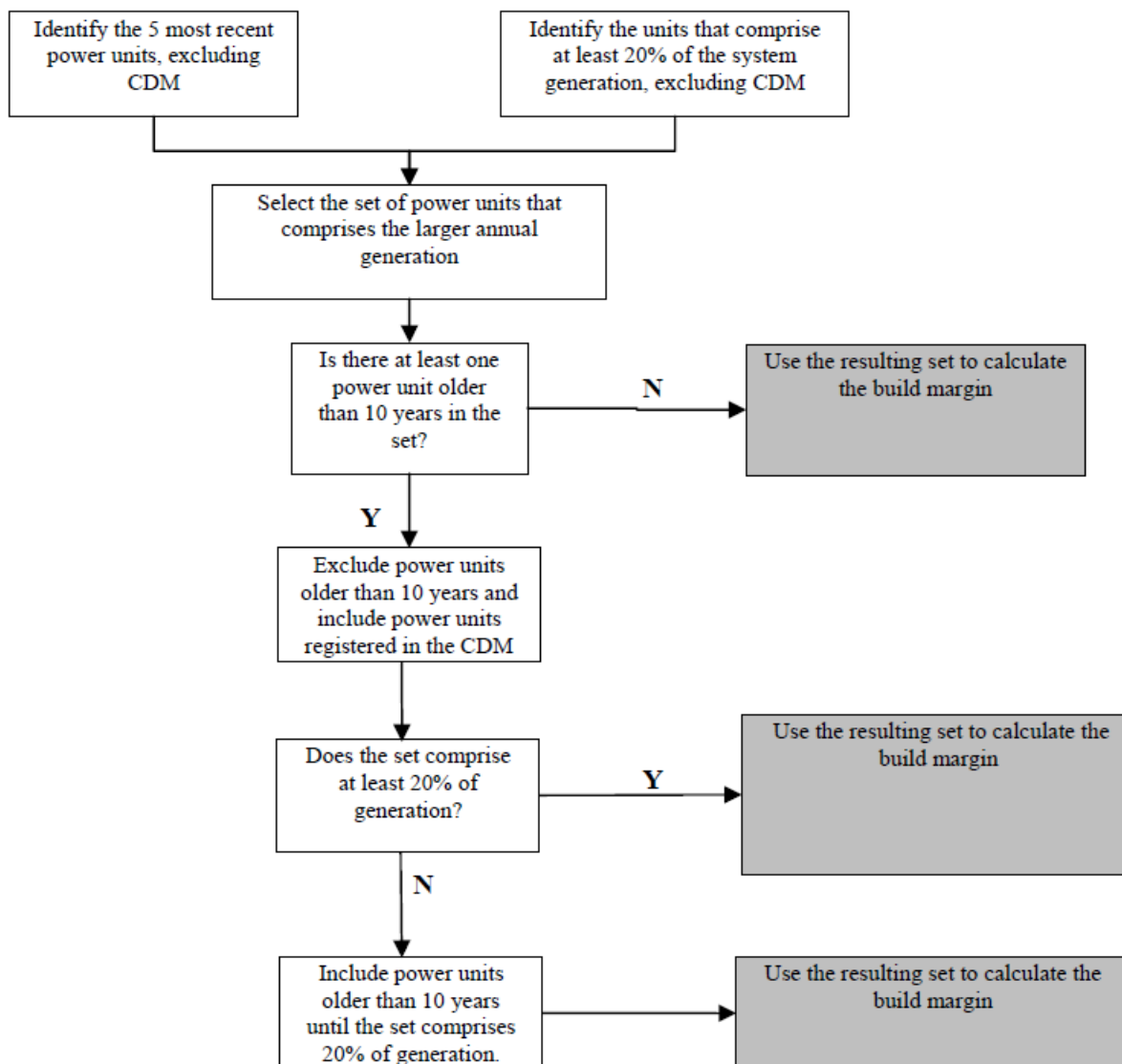

The build margin emissions factor is the generation-weighted average emission factor (tCO₂/MWh) of all power units *m* during the most recent year *y* for which power generation data is available, calculated as follows:

$$EF_{grid,BM,y} = \frac{\sum_m EG_{m,y} \times EF_{EL,m,y}}{\sum_m EG_{m,y}} \quad (13)$$

Where:

- $EF_{grid,BM,y}$ = Build margin CO₂ emission factor in year *y* (tCO₂/MWh)
- $EG_{m,y}$ = Net quantity of electricity generated and delivered to the grid by power unit *m* in year *y* (MWh)
- $EF_{EL,m,y}$ = CO₂ emission factor of power unit *m* in year *y* (tCO₂/GJ)

CDM – Executive Board

- m = Power units included in the build margin
- y = Most recent historical year for which power generation data is available.

The CO₂ emission factor of each power unit m ($EF_{EL,m,y}$) should be determined as per the guidance in Step 4 (a) for the simple OM, using **Option A1** using for y the most recent historical year for which power generation data is available, and using for m the power units included in the build margin. If for a power unit m data on fuel consumption and electricity generation is available the emission factor ($EF_{EL,m,y}$) should be determined as follows:

$$EF_{EL,m,y} = \frac{\sum_i FC_{i,m,y} \times NCV_{i,y} \times EF_{CO_2,i,y}}{\sum_m EG_{m,y}} \quad (2)$$

Where:

- $EF_{EL,m,y}$ = CO₂ emission factor of power unit m in year y (tCO₂/MWh)
- $FC_{i,m,y}$ = Amount of fossil fuel type i consumed by power unit m in year y (mass or volume unit)
- $NCV_{i,y}$ = Net calorific value (energy content) fossil fuel type i in year y (GJ/mass or volume)
- $EF_{CO_2,i,y}$ = CO₂ emission factor of fossil fuel type i in year y (tCO₂/GJ)
- $EG_{m,y}$ = Net electricity generated and delivered to the grid by power unit m in year y (MWh)
- m = All power plants/units serving the grid in year y except low-cost/must-run power plants/units
- i = All fossil fuel types combusted in power plant/unit m in year y
- y = The relevant year as per data vintage chosen in Step 3.

Using equation 13, the BM is calculated as **1.0378** tCO₂e/MWh.

STEP 6: CALCULATE THE COMBINED MARGIN (CM) EMISSION FACTOR

The combined margin factor is calculated as follows:

$$EF_{grid,CM,y} = EF_{grid,OM,y} \times w_{OM} + EF_{grid,BM,y} \times w_{BM} \quad (14)$$

Where:

- $EF_{grid,BM,y}$ = Build Margin CO₂ emission factor in year y (tCO₂/MWh)
- $EF_{grid,OM,y}$ = Operating margin CO₂ emission factor in year y (tCO₂/MWh)
- w_{OM} = Weighting of operating margin emissions factor (%)
- w_{BM} = Weighting of build margin emissions factor (%)

The emission factors for the operating margin, the build margin, and the final combined margin appear in Table 8.

Table 3: CM emission factor

CDM – Executive Board

$EF_{grid,OM,y}$	1.0182
$EF_{grid,BM,y}$	1.0378
w_{OM}	0.5
w_{BM}	0.5
$EF_{grid,CM,y}$	1.028

Annex 4

MONITORING INFORMATION
